

S/AVM-C



Made in Italy

SIL FIM SRL
Via Campania 19
60035 Jesi (AN)
Italy

Tel: (+39) 0731 21801
Fax: (+39) 0731 200355
informa@silcspa.it
www.silcspa.it



Tavolo da stiro rettangolare con piano riscaldato a vapore, aspirante e vaporizzante - dimensioni piano cm. 160x80. Da collegare a fonti esterne di vapore, aspirazione e aria compressa. Valvola pneumatica d'aspirazione inclusa.



Rectangular ironing table with steam heated, vacuum and steaming board - table top dimensions cm. 160x80. To be connected to central steam, vacuum and compressed air. Pneumatic vacuum valve included.



Table a repasser rectangulaire avec plateau réchauffée à vapeur, aspirant et vaporisant - dimensions plateau cm. 160x80. A brancher vapeur, aspiration et air comprimé centrales. Valve pneumatique d'aspiration compris.

ACCESSORI - ACCESSORIES - ACCESSOIRES

- Gruppo ferrovapore – Steam iron group – Groupe fer à vapeur
- Ferro da stiro - Steam iron - Fer à repasser
- Braccio con forme stiramaniche e cuscino - Arm with sleeve and pillow forms - Bras avec forme jeannette et coussin
- Dispositivi di smacchiatura a caldo e freddo - Hot and cold spotting devices - Dispositifs de détachage à froid et chaud
- Automazione con timer – Automation by timers – Automation avec temporisateurs
- Piano inclinato – Inclined table top – Plateau incliné
- Telaio fermacapi – Garment frame – Cadre supérieur
- Gruppo supporto ferro con illuminazione - Iron support group with lighting - Groupe support de fer avec illumination

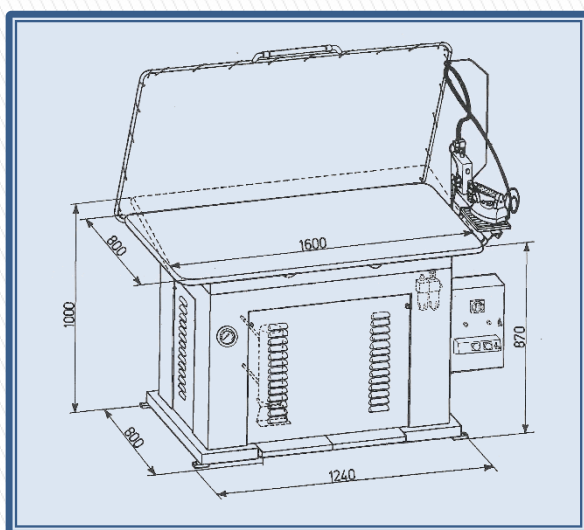
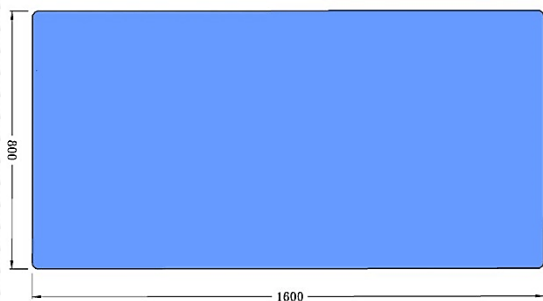

DATI TECNICI - TECHNICAL DATA - DONNESS TECHNIQUES

Voltaggio - Voltage - Voltage	230/50/1
Potenza - Power - Puissance	0,1 kW
Consumo vapore - Steam Consumption - Consommation vapeur	15-20 kg/h (5 bar)
Aria compressa – Compressed air – Air comprimé	6 bar
Peso netto - Net weight - Poids net	215 kg