

# S/AVRM-S



*Made in Italy*

**SIL FIM SRL**  
Via Campania 19  
60035 Jesi (AN)  
Italy

Tel: (+39) 0731 21801  
Fax: (+39) 0731 200355  
informa@silcspa.it  
www.silcspa.it



Tavolo da stiro rettangolare autonomo con piano riscaldato a vapore, aspirante, vaporizzante e soffiante - dimensioni piano cm. 160x80. Completo di generatore di vapore a norme europee "PED" ed aspiratore incorporati. Alimentazione acqua con pompa incorporata. Scambio aspirazione/soffiaggio pneumatico. Da collegare a fonte esterna di aria compressa.



Self-contained rectangular ironing table with steam heated, vacuum, steaming and blowing board - table top dimensions cm. 160x80. Provided with built-in electric boiler according to European "PED" standards and vacuum group. Automatic water feed by the means of built-in pump. Pneumatic vacuum/blowing exchange. To be connected to central compressed air.



Table a repasser rectangulaire autonome avec plateau réchauffée à vapeur, aspirant, vaporisant et soufflant - dimensions plateau cm. 160x80. Avec aspirateur et chaudière électrique a normes Européennes « PED » incorporés. Alimentation eau automatique par pompe incorporée. Echangé aspiration/soufflage pneumatique. A brancher air comprimé centrale.

### ACCESSORI - ACCESSORIES - ACCESSOIRES

- Ferro da stiro - Steam iron - Fer à repasser
- Braccio con forme stiramaniche e cuscino - Arm with sleeve and pillow forms - Bras avec forme jeannette et coussin
- Pistola nebulizzatrice acqua - Water spray gun - Pistolet pulvérisateur eau
- Dispositivi di smacchiatura a caldo e freddo - Hot and cold spotting devices - Dispositifs de détachage à froid et chaud
- Automazione con timer - Automation by timers - Automation avec temporisateurs
- Piano inclinato - Inclined table top - Plateau incliné
- Telaio fermacapi - Garment frame - Cadre supérieur
- Gruppo supporto ferro con illuminazione - Iron support group with lighting - Groupe support de fer avec illumination

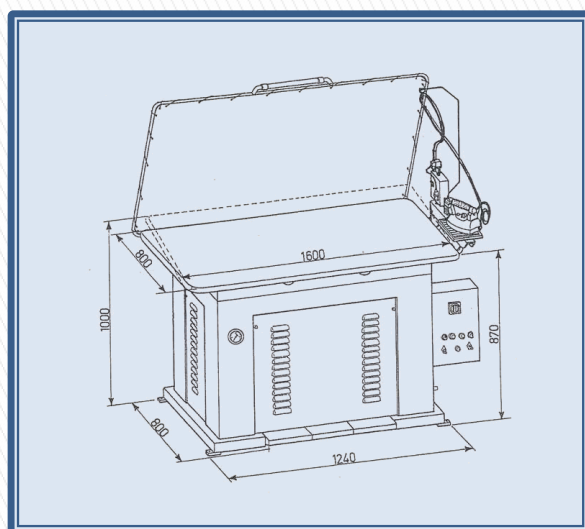
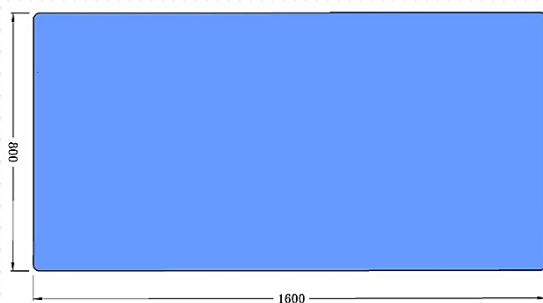

### DATI TECNICI - TECHNICAL DATA - DONNESS TECHNIQUES

Voltaggio - Voltage - Voltage	400/50/3
Potenza - Power - Puissance	13 kW
Caldaia - Boiler - Chaudière	24 L (12 kW)
Produzione vapore - Steam production - Production vapeur	16-20 kg/h (5 bar)
Aria compressa - Compressed air - Air comprimé	40 L/min (6 bar)
Pompa acqua - Water pump - Pompe eau	0,55 kW
Aspiratore - Vacuum - Aspirateur	0,372 kW
Peso netto - Net weight - Poids net	290 kg